

Jackfish Electrochemical Cells

AT A GLANCE

- ▶ Cells construction materials compatible with organic solvents and acidic/basic media
- ▶ Reliable electrical contact with metal thin-film electrode
- ▶ Easy installation on the VeeMAX III ATR accessory
- ▶ Two ATR crystal geometries available to accommodate VeeMAX ATR crystals or ATR Si wafers

Jackfish spectroelectrochemical cells (SEC) are designed for surface-sensitive FTIR spectroelectrochemistry using the attenuated total reflectance surface-enhanced infrared spectroscopy (ATR-SEIRAS) technique.

The Jackfish cells enable fundamental studies of the electrified metal-solution interface and have applications in molecular self-assembly, interfacial sensing, and next-generation energy solutions. High-quality IR spectra can be obtained from sub-monolayer amounts of adsorbed molecules. By controlling the electrical potential applied to the metal thin film electrode on the ATR crystal surface, the user can perform vibrational characterization of potential-dependent changes at the interface.

THE JACKFISH DESIGN

CELL DESIGN

Two cell models are available, J1 and J2. Both are fully compatible with the PIKE VeeMAX III variable angle ATR sampling accessory, and are constructed from highly chemical-resistant polyether ether ketone (PEEK) and glass for a broad range of aqueous or organic solution conditions.

J1

The J1 uses ground glass joints designed for use with aqueous electrolytes and offers a reference arm separated with a stopcock, which acts as a salt bridge preventing migration of the reference electrode filling solution into the cell body. There are three ports at the top of the cell and side ports for a reference electrode arm and a short bubbler. Typical uses of the ports are to support the counter electrode, and to accommodate glass bubblers and an exhaust gas trap. The long glass bubbler allows sparging of the solution volume with inert gas to remove atmospheric oxygen, enabling high-quality electrochemistry and ensuring stability of the thin film electrode. The short gas bubbler is used to create an inert atmosphere above the electrolyte. The minimum cell volume for the J1 is 20 mL.

J2

The J2 offers a simple sealed design compatible with volatile solvents, where the electrodes are inserted directly into the cell in close proximity to the working electrode, reducing the impedance to the reference electrode. With a compression-style fitting, the J2 accepts reference electrodes having diameters between 5 and 7 mm. The completely sealed design can be used with Schlenk techniques or in a glovebox. The minimum cell volume for the J2 is 10 mL.



The Jackfish cell designs make connecting with the metal thin film electrode easy. The PEEK reservoir has embedded spring-loaded pins, which contact the metal thin film electrode outside of the solution. This innovative design maintains superior electrical contact over long experiments without degrading the thin film electrode.



The Jackfish J2 model

ATR ELEMENTS

Two ATR element geometries are available for maximum flexibility. The J1F and J2F models are designed around the PIKE face-angled crystals (FAC). In a previous study investigating the adsorption of a pyridine derivative, the spectral response was two times stronger when using a Si 60 degree FAC compared to a Si hemisphere with an angle of incidence of 65 degrees. The FAC exhibited higher energy throughput and lower spectral noise above the long-wavelength cutoff.

The J1W and J2W models accommodate a microgrooved Si ATR wafer. The shorter pathlength (relative to a FAC or hemisphere), of the beam through the wafer mitigates losses due to Si phonon absorption, allowing the user complete access to the fingerprint and far-IR spectral regions. Additionally, wafers are inexpensive and can be recycled or disposed. Two wafer designs are available. The ATR-SEIRAS optimized wafer has an angle of incidence of 55 degrees, and is typically used for direct thin film deposit onto the Si wafer. The universal wafer has an angle of incidence of 35 degrees and provides a robust and strongly enhancing surfaces for hybrid films formed by electrodepositing metal island layers on conductive metal oxide films.

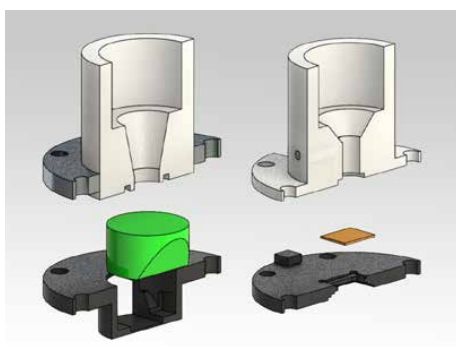

Left: Jackfish model J1F/J2F.
Right: Jackfish model J1W/J2W.

APPLICATION

Attenuated total reflection surface enhanced infrared spectroscopy (ATR-SEIRAS) has emerged as an alternative to external reflection based IR spectroelectrochemistry, and has been shown to be a powerful, highly surface-sensitive tool for the analysis of molecules present at electrode surfaces.

The ATR-SEIRAS method has seen increasing popularity in small molecule catalysis, particularly adept at elucidating mechanistic details concerning CO₂ electroreduction.

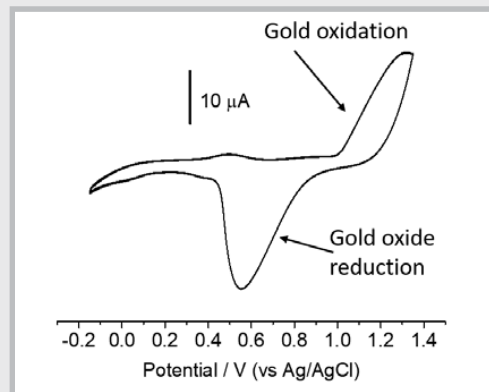

A typical CV of gold electropolishing using acetate buffer, using 100 mM acetate at pH 3.6 and a 20 mV/sec scan rate and Ag/AgCl reference electrode.

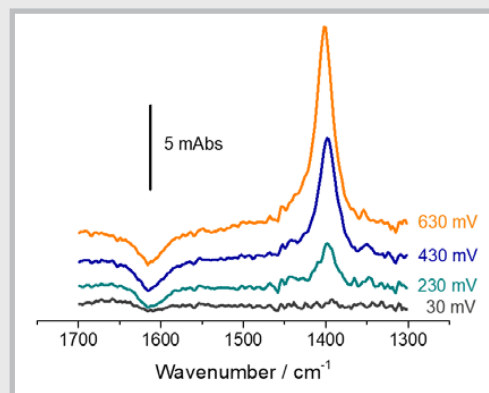

Potential dependence of symmetric COO⁻ stretching of adsorbed acetate on clean gold surface after electropolishing procedure. Absorbance spectrum for 630 mV, 430 mV, 230 mV, and 30 mV (vs Ag/AgCl) are all referenced to -100 mV (vs Ag/AgCl).

BACKGROUND

Jackfish SEC was founded in 2018 in Saskatoon, Canada by electrochemists at the University of Saskatchewan. The team has spent 10 years designing, innovating and testing spectroelectrochemical cells for attenuated total reflectance surface-enhanced infrared spectroscopy (ATR-SEIRAS). A decade of experiment-based design improvements has led to an innovative and commercially available ATR-SEIRAS cell design. Jackfish SEC is dedicated to making advanced infrared spectroelectrochemical technology easily accessible to new users with off-the-shelf solutions that allow you to easily equip your laboratory with ATR-SEIRAS capabilities.

SELECTED REFERENCES

Optimization of a Commercial Variable Angle Accessory for Entry Level Users of Electrochemical Attenuated Total Reflection Surface Enhanced Infrared Absorption Spectroscopy (ATR-SEIRAS). Applied Spectroscopy. 2019; 73(12), 1394-1402.

Hybrid Gold–Conductive Metal Oxide Films for Attenuated Total Reflectance Surface Enhanced Infrared Absorption Spectroscopy. ACS Applied Nano Materials. 2019; 2, 1274.

Electrochemical ATR-SEIRAS Using Low-Cost, Micromachined Si Wafers. Analytical Chemistry. 2017; 89, 11818–11824.

Surface Enhanced Infrared Studies of 4-Methoxypyridine Adsorption on Gold Film Electrodes. Langmuir. 2016; 32, 2184-2191.

Charge Transfer and SEIRAS Studies of 1,4-Benzoquinone Functionalized Mixed Monothiol/Dithiol Self Assembled Monolayers. Electrochimica Acta. 2011; 56, 4361-4368.

Surface Enhanced Infrared Absorption Spectroscopy Studies of DMAP Adsorption on Gold Surfaces. Langmuir. 2009; 25, 2241-2247.

Electrodeposited Gold Nanodaggers on Conductive Metal Oxide Films Provide Substrates for Dual-Modality Surface Sensitive Vibrational Spectroscopy. Journal of Physical Chemistry C. 2020; 124, 13356-13364.

Microsecond Resolved Infrared Spectroelectrochemistry Using Dual Frequency Comb IR Lasers. Analytical Chemistry. 2020; 92, 6241-6244.

PART NUMBER	DESCRIPTION
162-4709	Jackfish SEC Cell J1F
162-4714	Jackfish SEC Cell J1W
162-4719	Jackfish SEC Combination Cell J1
162-4701	Jackfish SEC Cell J2F
162-4702	Jackfish SEC Cell J2W
162-4703	Jackfish SEC Combination Cell J2
013-11XX	VeeMAX III Variable Angle Specular Reflectance Accessory Includes specular reflectance masks (2, 5/8" and 3/8"), purge tubes, purge kit and spectrometer base mount.
013-13XX	VeeMAX III Laser

Notes: Replace XX with your spectrometer's Instrument Code listed in the back of the catalog. The VeeMAX III is required for use of the Jackfish SEC Cell. The SEC Combination Cell is compatible with standard VeeMAX face-angled crystals or Si wafer elements. SEC cell base is PEEK; PTFE configurations are available upon request. The J2 models include a Ag/AgCl reference electrode. The VeeMAX III Laser accessory is designed for instruments having a collimated beam.

Crystal Options (*choose at least one*)

160-5552	Si FAC Crystal, 60°
160-5550	ZnSe FAC Crystal, 60°
160-5551	Ge FAC Crystal, 60°
162-4814	J1W, J2W Universal ATR Si elements (2)
162-4816	J1W, J2W ATR-SEIRAS Optimized Si elements (2)

Notes: The 60° Si crystal is the user preferred option. The J1W and J2W cells are compatible with 162-4814 and 162-4816. See VeeMAX III with ATR for other crystal options.

Electrodes

162-4720	J1 Platinum Counter Electrode
162-4722	J1 Gold Counter Electrode
162-4723	J1 Ag/AgCl Reference Electrode
162-4768	J2 Platinum Counter Electrode
162-4767	J2 Gold Counter Electrode
162-4769	J2 Ag/AgCl Ref Electrode

Note: The Platinum Counter Electrode and Ag/AgCl Reference Electrode are user-preferred options. J2 model includes a Ag/AgCl reference electrode.

Replacement Parts and Options

162-4724	J1F/J2F Lower Viton® O-ring
162-4725	J1W/J2W Lower Viton® O-ring
162-4726	Upper Viton O-ring
162-4728	J1F/J2F Lower Perfluoroelastomer O-ring
162-4729	J1W/J2W Lower Perfluoroelastomer O-ring
162-4730	Upper Perfluoroelastomer O-ring
162-4732	Electroless Deposition Fixture

Note: Please contact PIKE Technologies for parts not found here.

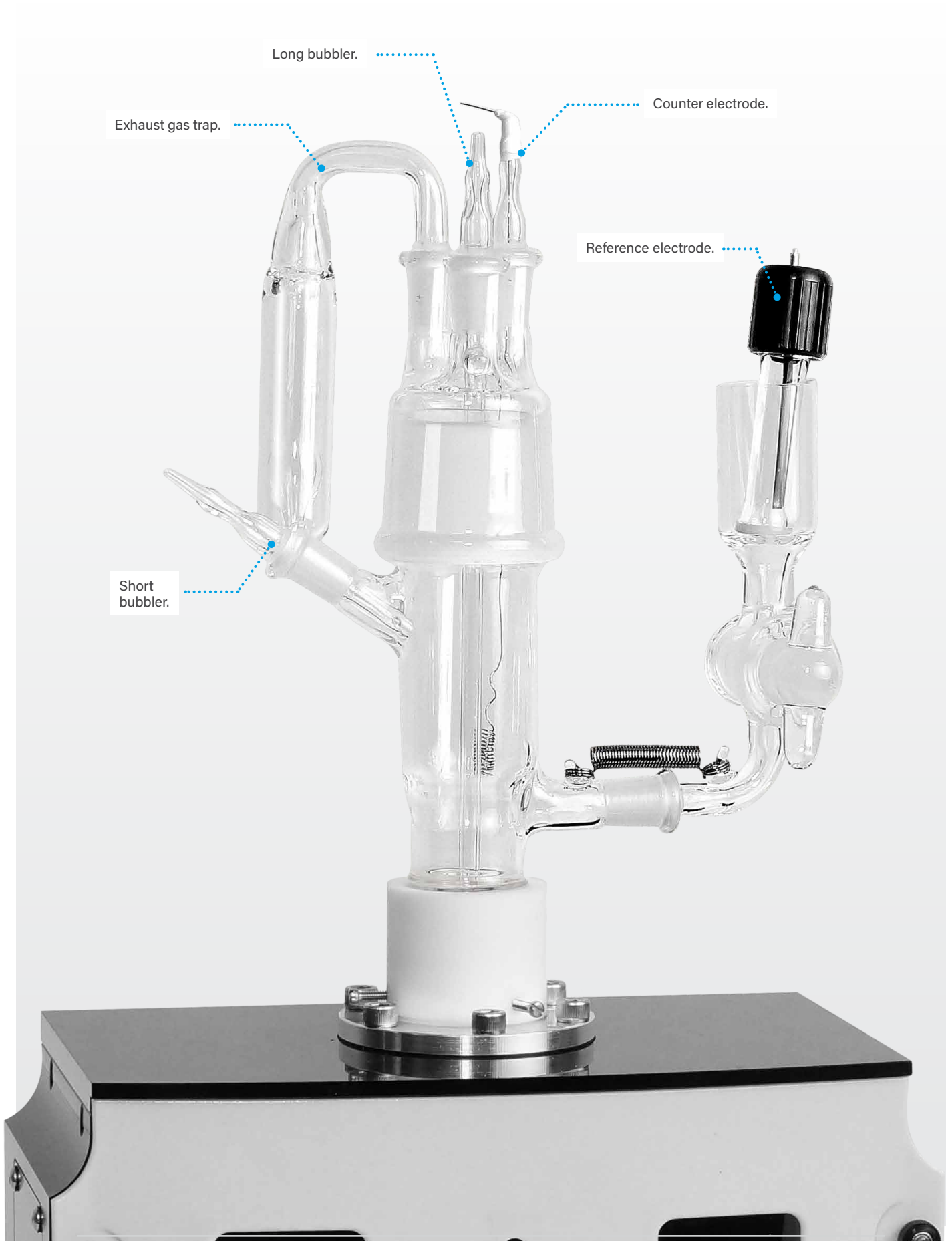

Long bubbler.

Exhaust gas trap.

Counter electrode.

Reference electrode.

Short bubbler.